

# NO. 63 & 055 ADJUSTABLE BAR FOLDERS

## INSTRUCTIONS AND PARTS LIST

For S Clips and Drive Cleats, forming sharp locks on edge of sheet metal for double seam, open locks for wired edges, flanges of various degrees, and single or double hems. For radius bends, short-run production, quick-set gauging. One motion to clamp and fold. Steel cabinet stand extra.

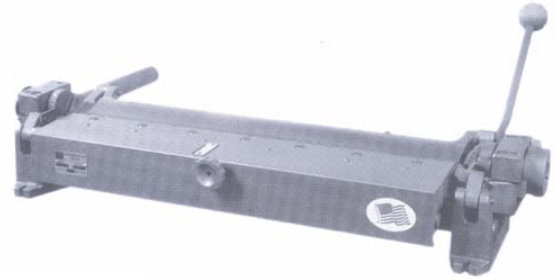

Number	63	055
Folding Length	30"	36"
Capacity, Mild Steel/Max Gauge	22	20
Gauging Range	1/8-1"	1/8-1 1/4"
Max. Round Fold Dia. (for wire)	1/4"	3/8"
Shipping Weight, Boxed (approx)	240 lbs	420 lbs
Shipping Weight, Stand (approx)	100 lbs	150 lbs

### INSTRUCTIONS

**CAUTION!** Before operating, machine must be bolted to work bench. If pedestal has been provided, machine must be bolted to pedestal with bolts provided. Pedestal must be lagged to floor. Failure to comply will result in machine tipping over, and may cause machine damage or bodily injury.

1. Mount Bar Folder on bench with Counterbalance and Handle facing towards rear of bench.
2. Gauge is adjustable from 1/8" to 1" or 1 1/4" depending on size of Folder. To adjust Gauge, turn Hand Knob (33). This moves Gauge Indicator to desired depth of lock.
3. Wedge adjustment is necessary for open or round locks. To adjust Wedge: (a) loosen two Knobs (20) on Folding Bar (4), (b) raise Folding Bar (4) to almost a right angle with edge of Folding Blade (17), (c) slide Knobs (20) to right to raise Wing (5), or to left to lower Wing (5) to any desired lock within the capacity of the Machine. Always allow a minimum clearance of the thickness of the metal being folded between the Wing (5) and the edge of the Blade (17). After the correct adjustment has been made, tighten Wedge Locking Knobs (20) to lock position.
4. For adjustment of clamping action between Blade (17) and Jaw (2), (a) bring Folding Bar (4) to almost a right angle with edge of Folding Blade (17), (b) adjust Set Screws (43) in Shoes (22) located at both ends of machine until Jaw (2) is flush against Folding Blade (17), (c) test with heavy paper for even grip the full length of Blade (17), (d) lock Set Screws (43) in Shoes (22) in place.

This adjustment is set when machine leaves factory for single lock operation. For double lock operation, more clearance is required between Jaw (2) and Folding Blade (17). To obtain correct clearance follow Instruction 4. After desired clearance is secured, adjust Wedges (15) and Wing (5) to suite Jaw (2) and Blade (17).

5. For bending angles of 45 degrees or 90 degrees set Stops (28) provide for respective angles at either end of machine. An adjustable Stop (35) for any angles from 10 degrees to 120 degrees is located at right of operator.
6. Lubricate all Bearings and moving parts with a medium (SAE 30) motor oil.



**ROPER WHITNEY OF ROCKFORD, INC.**

2833 HUFFMAN BLVD., ROCKFORD, ILLINOIS 61103-3990 \* 815/962-3011 \* FAX 815/962-2227

Website: [www.roperswhitney.com](http://www.roperswhitney.com) \* Email: [info@roperswhitney.com](mailto:info@roperswhitney.com)

Rev. 10/29/01

# NO. 63 & 055 ADJUSTABLE BAR FOLDERS

## PARTS IDENTIFICATION CHART

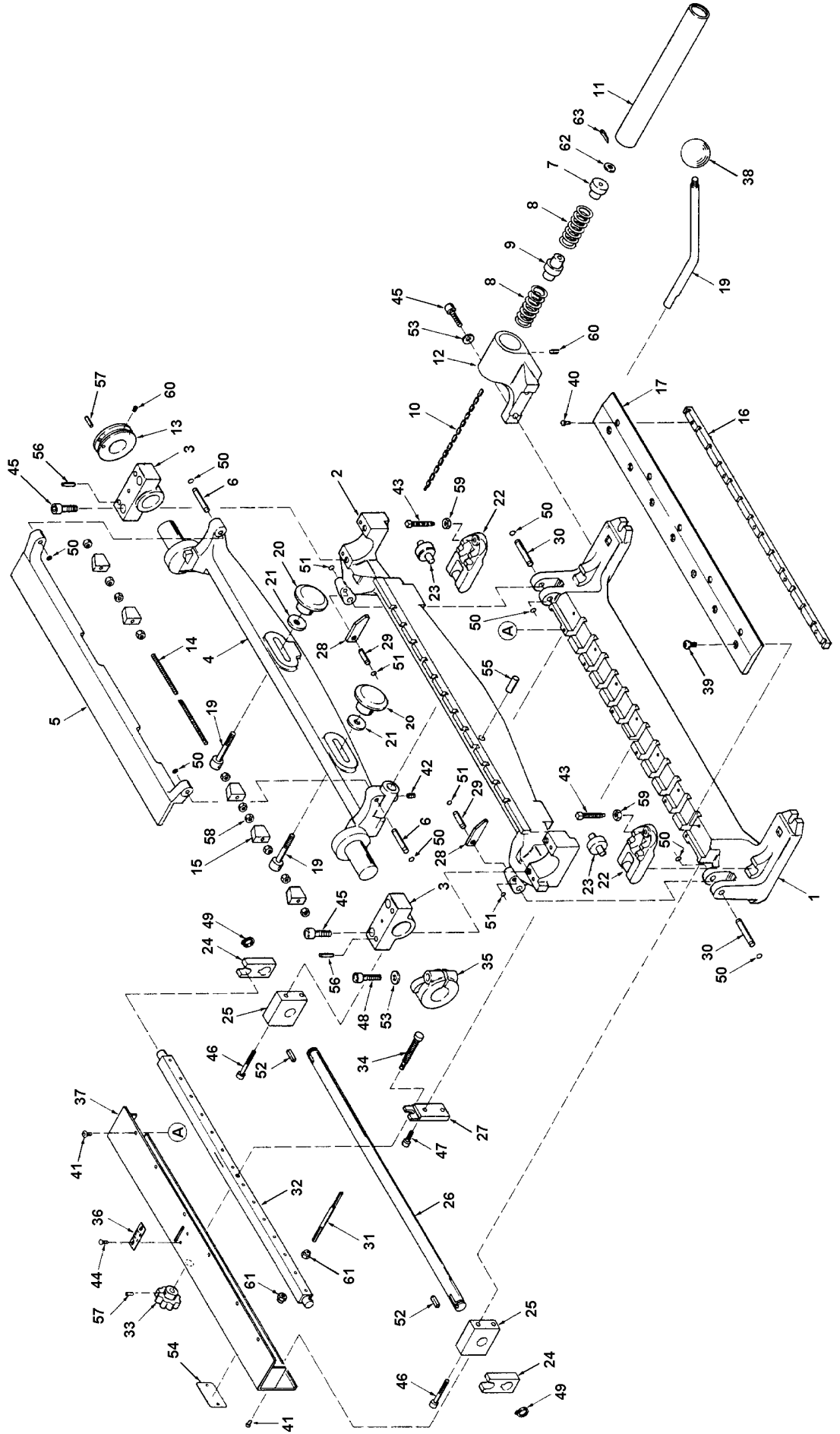

**NO. 63 & 055 ADJUSTABLE BAR FOLDERS  
PARTS IDENTIFICATION LIST**

<b>ITEM NO.</b>	<b>PART NO. NO. 63</b>	<b>PART NO. NO. 055</b>	<b>PART NAME</b>	<b>QTY.</b>
1	756140036	756140032	Frame	1
2	756020037	756020033	Jaw	1
3	756130017	756130017	Block, Pillow	2
4	756030038	756030034	Folding Bar	1
5	756020039	756020030	Wing	1
6	756160040	756160001	Pin, Pivot Grooved	2
7	756080002	756080002	Bushing	1
8	656184513	656184513	Spring, Compression	2
9	756080003	756080003	Bushing	1
10	756000051	756000051	#50 Plain Finish Chain-Sash 13/16 L. x 3/8 W.	1
11	756000004	756000004	Container, Spring	1
12	756200031	756200031	Bracket, Counterbalance	1
13	756000005	756000005	Roll, Counterbalance	1
14	756650043	756650006	Screw, Wedge	1
15	591000001	591000001	Wedge	5
16	756450018	756450018	Guide, Gauge	1
17	756120044	756120019	Blade, Top	1
18	756460045	756460055	Handle	1
19	756010008	756010008	Clamp, Wedge	2
20	656356300	656356300	Knob	2
21	756630009	756630009	Spacer	2
22	756570049	756570021	Shoe, Adjustable	2
23	756000046	756000010	Roll, Lifting	2
24	756030022	756030022	Lever	2
25	756130011	756130011	Block, Mounting	2
26	756030023	756030023	Bar, Equalizer	1
27	756000024	756000024	Plate	1
28	756130047	756130012	Stop, Angle	2
29	756160041	756160013	Pin, Pivot Grooved	2
30	756160042	756160001	Pin, Pivot Grooved	2
31	756420048		Gauge	12
31		756420014	Gauge	14
32	756030025	756030025	Bar, Gauge	1
33	756550026	756550026	Knob	1
34	756650015	756650015	Screw, Adjusting	1
35	756260016	756260016	Collar, Stop	1
36	756300029	756300029	Scale	1
37	756220027	756220027	Cover	1
38	656356316		Ball Handle	1
38		656356316	Ball Handle	2
39	615012174		Screw, Soc. But. Hd. Cap 3/8-16 x 7/8	7
39		615012273	Screw, Soc. But. Hd. Cap 1/2-13 x 1 1/4	8

**NO. 63 & 055 ADJUSTABLE BAR FOLDERS  
PARTS IDENTIFICATION LIST**

<b>ITEM NO.</b>	<b>PART NO. NO. 63</b>	<b>PART NO. NO. 055</b>	<b>PART NAME</b>	<b>QTY.</b>
40	615012089	615012089	Screw, Soc. But. Hd. Cap 1/4-20 x 3/4	5
41	615012049	615012049	Screw, Soc. But. Hd. Cap #10-24 x 3/8	8
42	617012172		Screw, Soc. Set 3/8-16 x 5/8	1
42		617012168	Screw, Soc. Set 3/8-16 x 3/8	2
43	627012183		Screw, Sq. Hd. Set 3/8-16 x 2	2
43		627012280	Screw, Sq. Hd. Set 1/2-13 x 2 1/4	2
44	609012024	609012024	Screw, Rd. Hd. #8-32 x 1/4	2
45	611012277	611012277	Screw, Soc. Hd. Cap 1/2-13 x 1 3/4	6
46	611012143	611012143	Screw, Soc. Hd. Cap 5/16-18 x 2 1/2	4
47	611012133	611012133	Screw, Soc. Hd. Cap 5/16-18 x 1	2
48	601012281	601012281	Screw, Hex Hd. Cap 1/2-13 x 2 1/2	1
49	656164302	656164302	Ring, Retaining	2
50	656164300	656164301	Ring, Retaining	8
51	656164308	656164300	Ring, Retaining	4
52	701530810	701530810	Key, 1/4 x 1/4 x 5/8	2
53	656000017	656000017	Washer, Plain 1/2 - Std. SAE "N"	3
54	600346122	600346122	Nameplate	1
55	600053354		Pin, Dowel 1/2 x 1 1/2	1
55		600053356	Pin, Dowel 1/2 x 2	1
56	600053318	600053318	Pin, Dowel 1/4 x 1	4
57	600063455	600063455	Pin, Roll 3/16 x 1	1
58	656023021		Nut, Hex Lock 1/4-28 TWA	12
58		656023021	Nut, Hex Lock 1/4-28 TWA	14
59	649023005		Nut, Hex Jam 3/8-16	2
59		649023007	Nut, Hex Jam 1/2-13	2
60	621012126	621012126	Screw, Soc. Set Cup Point 5/16-18 x 3/8	2
61	652023003		Nut, Hex Jam 1/4-28	22
61		652023003	Nut, Hex Jam 1/4-28	26
62	600033128	600033128	Washer	1
63	600073538	600073538	Pin, Cotter 5/32 x 1	1

We disclaim any responsibility whatsoever to the customer or to any other person for injury to person, or damage to or loss of property or value, caused by any product which has been subjected to misuse, negligence or accident; or misapplied; or modified or repaired by unauthorized persons; or improperly installed. We shall in no event be liable for any consequential damage, loss or expense arising from the use of or inability to use our product.

## NO. 63 & 055 ADJUSTABLE BAR FOLDERS OPTIONAL PEDESTAL

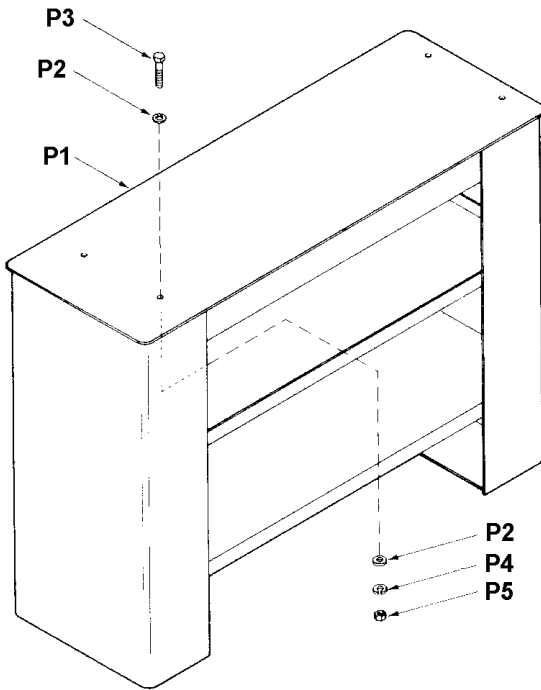

ITEM NO	PART NO.	PART NAME	QTY.
<b>PEDESTAL FOR NO. 63</b>			
P1	739060000	BENCH STAND, SHORT	1
P2	678033105	WASHER, FLAT 3/8	8
P3	601012180	SCREW, HHC 3/8-16 X 1 3/4	4
P4	679033105	WASHER, LOCK 3/8	4
P5	643023005	NUT, HEX FULL 3/8-16	4
<b>PEDESTAL FOR NO. 055</b>			
P1	739060001	BENCH STAND, LONG	1
P2	678033107	WASHER, FLAT 1/2	8
P3	601012275	SCREW, HHC 1/2-13 X 1 1/2	4
P4	679033107	WASHER, LOCK 1/2	4
P5	643023007	NUT, HEX FULL 1/2-13	4

### FORM DIAGRAM

